

HUAWEI E630 Data Card Product Description



HUAWEI E630 Data Card

Product Description

Document Version 02 (2006-07-05)

Product Version V100R001

BOM 31027478

Huawei Technologies Co., Ltd. provides customers with comprehensive technical support and service. Please feel free to contact our local office or company headquarters.

Huawei Technologies Co., Ltd.

Address: Administration Building, Huawei Technologies Co., Ltd.,

Bantian, Longgang District, Shenzhen, P. R. China

Postal Code: 518129

Website: <http://www.huawei.com>

Copyright © 2006 Huawei Technologies Co., Ltd.

All Rights Reserved.

No part of this manual may be reproduced or transmitted in any form or by any means without prior written consent of Huawei Technologies Co., Ltd.

Trademarks

(1)  and other Huawei trademarks are the trademarks or registered trademarks of Huawei Technologies Co., Ltd. in the People's Republic of China and certain other countries.

(2) All other trademarks and trade names mentioned in this document are the property of their respective holders.

Notice

The information in this manual is subject to change without notice. Every effort has been made in the preparation of this manual to ensure accuracy of the contents, but all statements, information, and recommendations in this manual do not constitute the warranty of any kind, express or implied.



Table of Contents

Chapter 1 Product Overview	1-1
Chapter 2 Product Features	2-1
2.1 Main Features	2-1
2.2 Main Technical Specifications	2-1
2.2.1 Hardware Specifications	2-1
2.2.2 Wireless Antenna Specifications.....	2-3
2.2.3 Software Specifications.....	2-4
2.2.4 Dashboard Specifications	2-5
Chapter 3 Services and Applications.....	3-1
3.1 SMS Service	3-1
3.2 Data Service	3-1
Chapter 4 System Architecture.....	4-1
4.1 Block Diagram of System Architecture	4-1
4.2 Introduction to the Functional Modules.....	4-1
Chapter 5 Packing List.....	5-1
Chapter 6 Technical Reference.....	6-1
6.1 Standards and Main Communication Protocols	6-1
6.1.1 Layer 1 Specifications(Physical)	6-1
6.1.2 Layer 2 Specifications(MAC/RLC)	6-1
6.1.3 Layer 3 Specifications(RRC).....	6-1
6.1.4 Layer 3 NAS/Core Network (MCM).....	6-1
6.1.5 GSM Protocol Specifications.....	6-1
6.1.6 GPRS Protocol Specifications.....	6-2
6.1.7 General Specifications	6-2
6.1.8 Performance/Test Specifications	6-2
6.1.9 SIM Specifications.....	6-3
Chapter 7 Acronyms and Abbreviations.....	7-1

Chapter 1 Product Overview

HUAWEI E630 Data Card is a wireless multi-mode terminal specifically for users of laptop on the basis of HSDPA (High Speed Downlink Packet Access)/WCDMA (Wideband Code Division Multiple Access)/GSM (Global System for Mobile Communications)/GPRS (General Packet Radio Service (System))/EDGE (Enhanced Data Rates for Global Evolution). E630 Data Card supports WCDMA/EDGE/GPRS PS domain (Packet Switched Domain) both data services and SMS service, WCDMA/GSM CS (Circuit Switched Domain) domain SMS service.

HUAWEI E630 Data Card can be connected to a laptop by PCMCIA (Personal Computer Memory Card International Association) Type II interface. In the coverage area of HSDPA/WCDMA or GPRS /EDGE /GSM network, you can enjoy the surfing without cables, send and receive SMS or e-mails. Its faster speed, more reliable performance and easier operation will create a new experience in mobile life.

Figure 1-1 shows the profile of E630 Data Card.



Figure 1-1 E630 Data Card

Chapter 2 Product Features

2.1 Main Features

The main features of HUAWEI E630 Data Card include:

- Supporting WCDMA/HSDPA 2100 MHz and GSM/GPRS/EDGE 900 MHz/1800 MHz/1900MHz
- Supporting HSDPA PS data service with a maximum transmission rate of 3.6 Mb/s DL (Downlink)
- Supporting WCDMA PS data service with a maximum transmission rate of 384 kbit/s UL (Uplink)
- Supporting EDGE PS data service with a maximum transmission rate of 236.8 kbit/s (UL/DL)
- Supporting GPRS PS data service with a maximum transmission rate of 85.6 kbit/s (UL/DL)
- Supporting CS SMS (Short Message Service) based on WCDMA/GSM, and SMS group transmission function
- Supporting PS data service based on WCDMA/EDGE/GPRS
- Supporting PS SMS service based on WCDMA/EDGE/GPRS, and SMS group transmission function
- The dashboard of E630 Data Card supports a high-capacity SMS box

2.2 Main Technical Specifications

2.2.1 Hardware Specifications

Table 2-1 lists the main hardware specifications of HUAWEI E630 Data Card.

Table 2-1 Hardware specifications

Item	Description	
Technical standard	<ul style="list-style-type: none">• HSDPA/WCDMA: 3GPP R5 2004/06• GSM/GPRS/EDGE: 3GPP R99 2003/12	
Operating frequency	WCDMA/HSDPA 2100 MHz	<ul style="list-style-type: none">• UL: 1920 MHz–1980 MHz• DL: 2110 MHz–2170 MHz
	GSM/GPRS/EDGE 900 MHz	<ul style="list-style-type: none">• UL: 880 MHz–915 MHz• DL: 925 MHz–960 MHz



Item	Description	
	GSM/GPRS/EDGE 1800 MHz	<ul style="list-style-type: none"> • UL: 1710 MHz–1785 MHz • DL: 1805 MHz–1880 MHz
	GSM/GPRS/EDGE 1900MHz	<ul style="list-style-type: none"> • UL: 1850MHz–1910MHz • DL: 1930MHz–1990MHz
External interface	PCMCIA interface	Type II, compliant with PC Card Release 8.1 CARDBUS standard
	LED	<ul style="list-style-type: none"> • Off when hardware is removed • Always on after the dial-up connection • Slow blinking (on or off every one second) on other status (including searching the network, idle, dialing and calling) • Green: indicating the data card is working in HSDPA/WCDMA mode • Blue: indicating the data card is working in GSM/GPRS/EDGE mode
	Antenna interface	Folding antenna, already configured with external antenna
	SIM/USIM card interface	Standard 6 PIN SIM card interface
Maximum transmitting power	<ul style="list-style-type: none"> • WCDMA /HSDPA 2100 MHz: + 24 dBm (Power Class 3) • GSM/GPRS 1800 MHz/1900 MHz: +30 dBm (Power class 1) • EDGE 900 MHz: +2 7 dBm (Power Class E2) • EDGE 1800 MHz/1900 MHz: + 26 dBm (Power Class E2) 	
Static receiving sensitivity	<ul style="list-style-type: none"> • WCDMA/HSDPA 2100 MHz: Compliant with 3GPP TS 25.101(R5) • GSM/GPRS/EDGE 900 MHz/1800 MHz/1900 MHz: Compliant with 3GPP TS 05.05 (R99) 	
Power consumption	Average power consumption ≤ 3 W	



Item	Description	
Power supply	750 mA 3.3 V, from PCMCIA card slot	
Dimensions	120 mm (L) × 54 mm (W) × 10 mm (H)	
Weight	About 55 g	
Temperature	Operating temperature	From -10 to 55 degrees centigrade
	Warehouse temperature	From -20 to 70 degrees centigrade
Humidity	5%–95%	
Notes: <i>LED: Light-emitting Diode</i> <i>SIM: Subscriber Identity Module</i> <i>USIM: UMTS Subscriber Identity Module</i>		

2.2.2 Wireless Antenna Specifications

Table 2-2 lists the technical specifications of antenna.

Table 2-2 Specifications of the external antenna

Item	Description
Frequency range	<ul style="list-style-type: none">• 824 MHz–960 MHz• 1710 MHz–2170 MHz
Input impedance	50 Ohm
Voltage Standing Wave Ratio	< 3
Gain	-2 dB/0 dBi
Power capacity	4 W
Polarization Type	Linear polarization
Operating temperature	From -30 to 60 degrees centigrade
Dimensions	42 *Φ 2 mm
Weight	20 g

Item	Description
Cable length	None
Annual failure rate	< 0.1%

2.2.3 Software Specifications

错误！未找到引用源。 lists the main software specifications of HUAWEI E630 Data Card.

Table 2-3 Software specifications

Item	Description
Data service	GSM CS <ul style="list-style-type: none"> • UL: 9.6 kbit/s • DL: 9.6 kbit/s
	GPRS <ul style="list-style-type: none"> • UL: 85.6 kbit/s (compliant with Multislot Class 12) • DL: 85.6 kbit/s
	EDGE <ul style="list-style-type: none"> • UL: 236.8 kbit/s (compliant with Multislot Class 12) • DL: 236.8 kbit/s
	WCDMA CS <ul style="list-style-type: none"> • UL: 64 kbit/s • DL: 64 kbit/s
	WCDMA PS <ul style="list-style-type: none"> • UL: 384 kbit/s • DL: 384 kbit/s
	WCDMA with HSDPA PS <ul style="list-style-type: none"> • UL: 384 kbit/s • DL: 3.6 Mbit/s
SMS service	<ul style="list-style-type: none"> • SMS service based on CS of WCDMA/GSM • SMS service based on PS of WCDMA/EDGE/GPRS
Operating	Supporting Windows 2000 and Windows XP operating systems

Item	Description
system	<p>Minimum system requirements:</p> <ul style="list-style-type: none"> • A Type II PCMCIA slot, supporting CARDBUS • CPU chip: 133 MHZ Pentium • Memory: 128 MB RAM • Spare hard disk capacity: 100 MB • Laptop resolution: 800 × 600 pixels <p>Recommended configuration:</p> <ul style="list-style-type: none"> • CPU chip: ≥ 500 MHz Pentium or above • Memory: ≥ 128 MB • Spare hard disk capacity: ≥ 100 MB <p>Laptop resolution: ≥ 1024 × 768 pixels</p>
<p>Note: AMR: Adaptive Multi-rate Codec</p>	

2.2.4 Dashboard Specifications

Table 2-4 lists the main specifications of the dashboard of HUAWEI E630.

Table 2-4 Specifications of the dashboard

Item	Description
SMS service	SMS writing: The maximum length of each message is 500 English characters and 250 Chinese characters
	SMS Sending and receiving: The maximum length of each message is 160 English characters and 70 Chinese characters
	SMS division: If a message to be sent contains characters more than the allowed maximum characters of message, it will be broken into two or more messages for sending
	SMS group transmission: A message can be sent to as much as 20 phone numbers once
	SMS Storage: It is the capacity of Outbox/Inbox/Draft box/Trash box/Report box and is subject to the capacity of the SIM/USIM or the hard disk space of laptop



Item	Description
	SMS sorting: You can sort messages by sender's/receiver's name, sending/receiving time, phone number, content and so on
	SMS import: You may import messages form the SIM/USIM card into the corresponding message boxes
	SMS ring prompt: It supports SMS ring prompt (Rings can be customized.)
Flow display and statistics (Data service)	Statistics of the flow of a current connection (including connection time, data flow, sending/receiving flow and rate, and maximum sending/receiving rate)
	Statistics of the previous flow (including sending/receiving flow and connection duration)
	Statistics of the total flow (including sending/receiving flow and connection duration)
Phone book	Phone book capacity: It is subject to the capacity of SIM/USIM card or the hard disk space of laptop
	Phone book management: name, phone numbers (including mobile phone, home numbers and office numbers), e-mail addresses and remarks
	Sending SMS messages directly from the phone book
	Phone book import/export: importing/exporting information between an E630 phone book and SIM/USIM card or files of a specified format



Item	Description
Other functions	Network connection settings (including auto/manual network selection and registration)
	Network status display (including signal strength, operator's name, system mode and so on)
	Selection of network connection types (WCDMA preferred, GSM preferred)
	PIN management: PIN authentication and modification PUK1 unlock
Notes: <ul style="list-style-type: none">• <i>PIN: Personal Identification Number</i>• <i>PUK: PIN Unblocking Key</i>	

Chapter 3 Services and Applications

3.1 SMS Service

HUAWEI E630 Data Card supports SMS service based on GSM and WCDMA CS domain, as well as SMS service based on WCDMA PS domain. By SMS settings of the dashboard, a user may choose a bearing domain (PS domain or CS domain) for sending messages.

HUAWEI E630 supports SMS writing, sending and receiving, and group transmission of messages up to 20 numbers simultaneously. The dashboard offers powerful SMS management function, including setting Outbox, Inbox, Draft box, Trash box and Report box, sorting by phone number or by time and exchanging SMS information between laptop and SIM/USIM.

3.2 Data Service

HUAWEI E630 Data Card supports CS domain data service based on WCDMA/GSM and PS domain data service based on HSDPA/WCDMA/EDGE/GPRS. A user may send/receive e-mails, browse the Internet, and download files through an established wireless data channel.

PS data service is usually launched by entering ***99#** or ***98#**. A user may choose a network type (WCDMA preferred, GSM preferred) on the **Connection Type** of the dashboard. The operating procedure for the CS data service and PS data service are almost the same expect their access number. You should consult the local service provider for the access number.

Chapter 4 System Architecture

4.1 Block Diagram of System Architecture

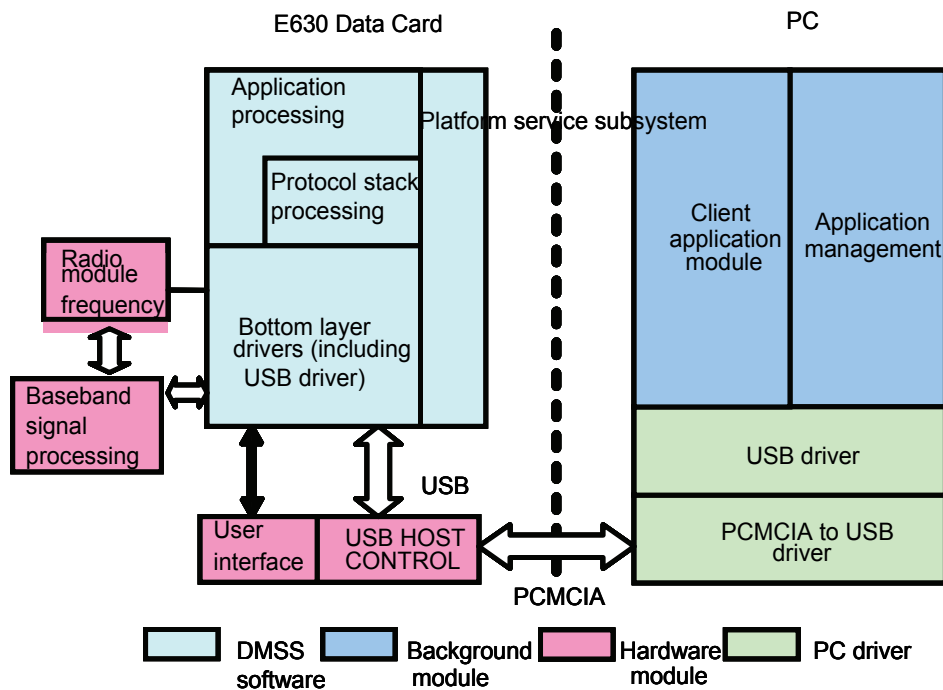

Figure 4-1 Block Diagram of System Architecture

4.2 Introduction to the Functional Modules

I. Radio Frequency Module:

It is mainly used for the data card to send/receive radio signals and to modulate/demodulate between radio frequency signals and baseband signals.

II. Baseband Signal Processing Module:

It is mainly used to perform the processing function of baseband digital signal of HSDPA/WCDMA/EDGE/GPRS/GSM, including HSDPA/WCDMA baseband modulation or demodulation, EDGE/GPRS/GSM baseband modulation and demodulation, HSDPA/WCDMA channel encoding or decoding, EDGE/GPRS/GSM channel encoding or decoding.

III. Bottom Layer Driver Module:

It is mainly used to drive peripherals, including USB (Universal Serial Bus), LED and SIM/USIM.

IV. Platform Service Subsystem Module:

It is mainly used for program initialization, diagnosis, downloads and serves as a watchdog.

V. Protocol Stack Processing Module:

It is responsible for processing Layer 2 and Layer 3 protocols of HSDPA/WCDMA/GSM/GPRS/EDGE.

VI. Application Processing Module

It is in charge of sending instructions from laptop to the bottom layer protocol for processing and then returning the value to laptop. Presently the main application includes call management, SMS management, CS/PS service management.

VII. User Interface Module

It offers E630 interfaces connecting peripherals. These interfaces include LED indicator and SIM/USIM interface.

VIII. USB HOST CONTROL

It is to convert USB interface to PCMCIA interface. PCMCIA to USB driver and USB driver, both functions are performed on the laptop and mainly used for exchanging information between the dashboard and data card.

IX. Application Management Module:

It offers the SMS sending/receiving function on the laptop side. It offers CS/PS domain Web browsing window. It refreshes the current state of the multi-mode data card periodically.

X. Client Application Module

It offers a main application window for a user to set parameters and to operate the data card.



Chapter 5 Packing List

Table 5-1 lists the HUAWEI E630 Data Card packing list.

Table 5-1 Packing list

Item	Quantity	Remarks
HUAWEI E630 Data Card	1	Standard
External Antenna	1	Optional
CD-ROM (including the Setup program)	1	Standard
HUAWEI E630 Data Card Quick Start	1	Standard
Certificate of Conformance	1	Standard

Chapter 6 Technical Reference

6.1 Standards and Main Communication Protocols

6.1.1 Layer 1 Specifications(Physical)

- Examples of Channel Coding and Multiplexing TR 25.944
- Physical Layer – General Description TS 25.201
- Physical Channels and Mapping of Transport Channels onto Physical Channels (FDD) TS 25.211
- Multiplexing and Channel Coding (FDD) TS 25.212
- Spreading and Modulation (FDD) TS 25.213
- Physical Layer – Procedures (FDD) TS 25.214
- Physical Layer – Measurements (FDD) TS 25.215
- 3GPP HSDPA overall description 25.308
- 3GPP UE radio access capabilities 25.306

6.1.2 Layer 2 Specifications(MAC/RLC)

- MAC Protocol Specification TS 25.321
- RLC Protocol Specification TS 25.322

6.1.3 Layer 3 Specifications(RRC)

- UE Interlayer Procedures in Connected Mode TS 25.303
- UE Procedures in Idle Mode TS 25.304
- RRC Protocol Specification TS 25.331

6.1.4 Layer 3 NAS/Core Network (MCM)

- Architectural Requirements for Release 1999 TS 23.121
- NAS Functions Related to Mobile Station (MS) in Idle Mode TS 23.122
- Mobile Radio Interface Signaling Layer 3 – General Aspects TS 24.007
- Mobile Radio Interface Layer 3 Specification – Core Network TS 24.008
- PP SMS Support on Mobile Radio Interface TS24.011

6.1.5 GSM Protocol Specifications

- Mobile Radio Interface Layer 3 Specification, Radio Resource Control Protocol TS 04.18
- Mobile Station - Base Station System (MS - BSS) interface; Data Link (DL) Layer Specification TS 04.06

- Digital Cellular Telecommunications System (Phase 2+); Multiplexing and Multiple Access on the Radio Path TS 05.02
- Technical Specification Group GERAN; Channel coding TS 05.03
- Digital Cellular Telecommunications System (Phase 2+); Radio Subsystem Link Control TS 05.08
- Digital Cellular Telecommunications System (Phase 2+); Radio Subsystem Synchronization TS 05.10

6.1.6 GPRS Protocol Specifications

- Overall Description of the GPRS Radio Interface; stage 2 TS 3.64
- Mobile Radio Interface Layer 3 Specification TS 04.08
- Mobile Radio Interface Layer 3 Specification: Radio Resource Control Protocol TS 04.18
- General Packet Radio Service (GPRS); Mobile Station (MS) – Base Station System (BSS) interface; Radio Link Control / Medium Access Control (RLC/MAC) protocol TS 04.60
- Mobile Station - Serving GPRS Support Node (MS-SGSN) Logical Link Control (LLC) Layer Specification TS 04.64
- Mobile Station - Serving GPRS Support Node (MS-SGSN); Subnet Dependent Convergence Protocol (SNDTCP) TS 04.65
- Multiplexing and Multiple Access on the Radio Path TS 05.02
- Channel Coding TS 05.03
- Modulation TS 05.04
- Radio Transmission and Reception TS 05.05
- General Packet Radio Service (GPRS); Stage 1 TS 22.060
- Mobile Execution Environment (MexE) TS 23.057
- General Packet Radio Service (GPRS) Service description; stage 2 TS 23.060

6.1.7 General Specifications

- UE Capability Requirements TR 21.904
- UE Radio Access Capabilities TR 25.926
- Vocabulary TR 25.990
- Radio Interface Protocol Architecture TS 25.301
- Services Provided by the Physical Layer TS 25.302
- Synchronization in UTRAN Stage 2 TS 25.402

6.1.8 Performance/Test Specifications

- UE Radio Transmission and Reception (FDD) TS 25.101
- Common Test Environments for User Equipment (UE) TS 34.108
- Special Conformance Testing Functions TS 34.109



- Terminal Conformance Specification TS 34.121
- User Equipment (UE) Conformance Specification; Part 1: Protocol Conformance TS 34.123-1
- User Equipment (UE) Conformance Specification; Part 2: Protocol Conformance TS 34.123-2

6.1.9 SIM Specifications

- SIM and IC Card Requirements TS 21.111
- 3rd Generation Partnership Project Technical Specifications Group Terminals; SIM App. Toolkit (USAT) TS 31.111

Chapter 7 Acronyms and Abbreviations

C

CS	Circuit Switched Domain
CS #	Coding Scheme

D

DCS	Digital Cellular System
DL	Downlink

E

EDGE	Enhanced Data Rates for Global Evolution
------	--

G

GSM	Global System for Mobile Communications
GPRS	General Packet Radio Service (System)

H

HSDPA	High Speed Downlink Packet Access
-------	-----------------------------------

L

LED	Light-emitting Diode
-----	----------------------

M

MCS #	Modulation Coding Scheme
-------	--------------------------

P

PCMCIA	Personal Computer Memory Card International Association
PIN	Personal Identification Number
PS	Packet Switched Domain
PUK	PIN Unlocking Key

S

SIM	Subscriber Identity Module
-----	----------------------------



SMS	Short Message Service
U	
UL	Uplink
UMTS	Universal Mobile Telecommunications System
USB	Universal Serial Bus
USIM	UMTS Subscriber Identity Module
W	
WCDMA	Wideband Code Division Multiple Access