

Operating instructions

METTLER TOLEDO
BB balances

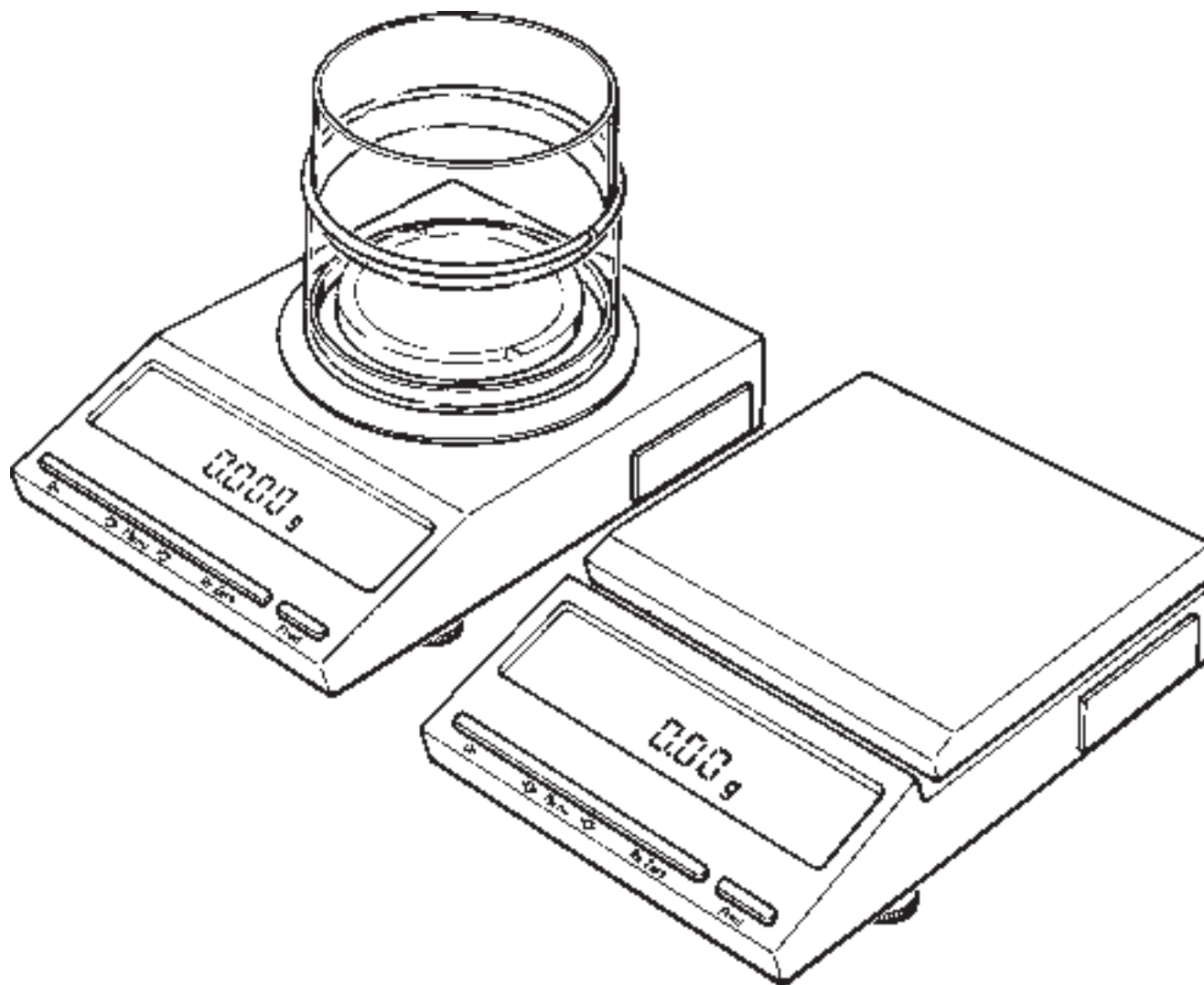

METTLER TOLEDO

Contents

1. Preparation	1.1 The right location	3
	1.2 To mount the round weighing pan	4
	1.3 To mount the square weighing pan	4
	1.4 Controls	5
	1.5 Connections	5
	1.6 Draft shield	6
	1.7 Hanger access	6
	1.8 Connecting the mains adapter (power supply)	7
	1.9 Leveling the balance	7
2. Operation	2.1 Display symbols	8
	2.2 Operating symbols	9
	2.3 Short instructions	10/11
	2.4 The menu	12
	2.5 Adjusting the balance to ambient conditions-Vibration adapter	13
	2.6 Adjusting the balance to the weighing process-Weighing process adapter	14
	2.7 Weighing under difficult conditions, weighing animals	15
	2.8 Adjusting the stability detector	16
3. Configuring	3.1 The configuration file	17
	3.2 To return to factory setting	18
	3.3 Selection of units	19
	3.4 Adjusting the interface to external equipment	20
	3.5 Securing the settings in the configuration file	21
4. Miscellaneous	4.1 To change the in-use cover	22
	4.2 Cleaning the balance	22
	4.3 Accessories	22
5. What to do if...	(A guide to trouble-shooting)	23

1. Preparation

Thank you for the confidence you have shown in us by choosing a METTLER TOLEDO precision balance. Read these instructions carefully to insure that the balance will perform to your complete satisfaction.

In Section 2.3 you will see some of the most important operations described in condensed form.

If - after thoroughly studying the entire instruction manual - you wish to refer frequently to this section, we recommend putting the instructions (open at these pages) in a plastic folder placed next to the balance or hung on the wall nearby.

Anyone using the balance then has a quick reference guide to the principal operations.

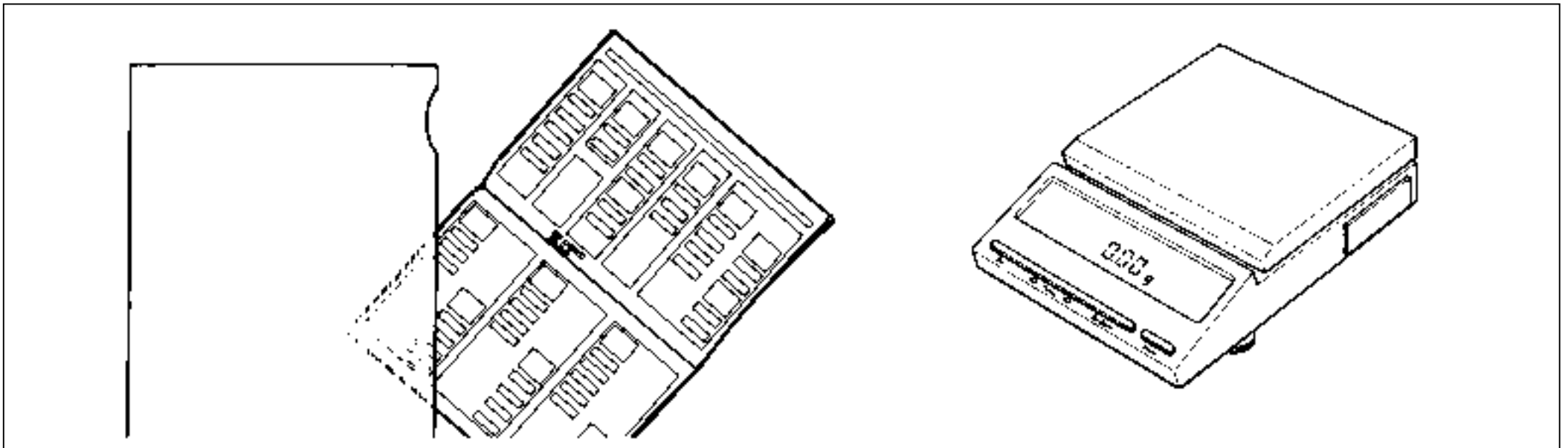

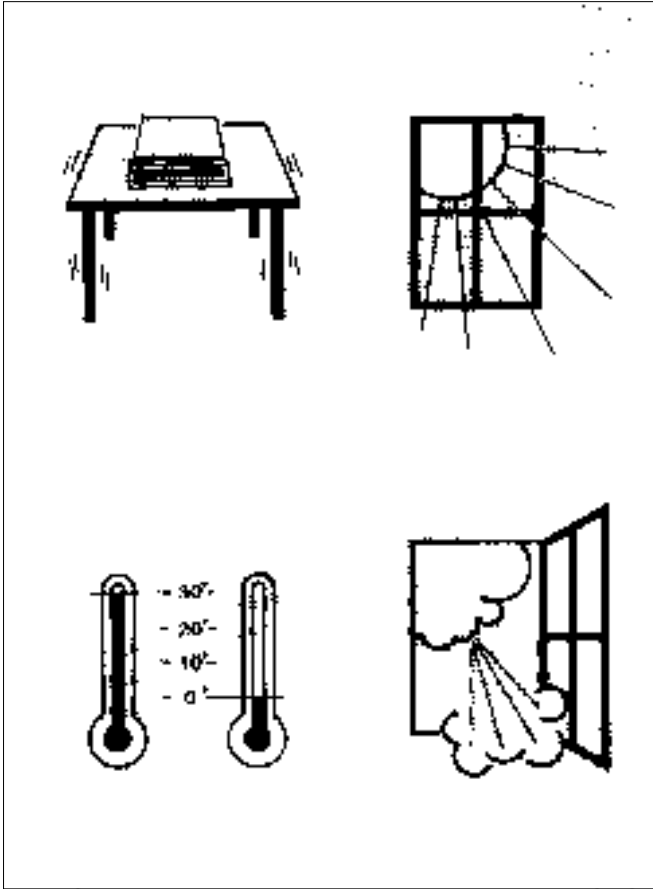

1.1 The right location

For best results choose a suitable location for your balance.

- A firm, horizontal surface with **minimum vibration!**
- Avoid direct **sunlight!**
- No extreme **temperature variations!**
- No **drafts!**

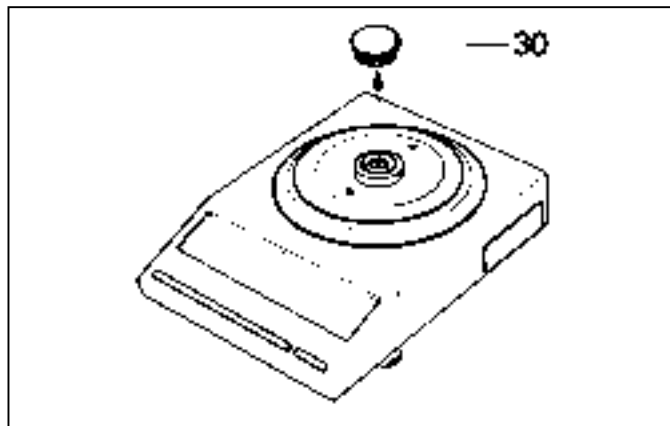

1.2 To mount the round weighing pan

If your balance has a round weighing pan, please remove the dust cap **30** which has protected the balance during shipment.

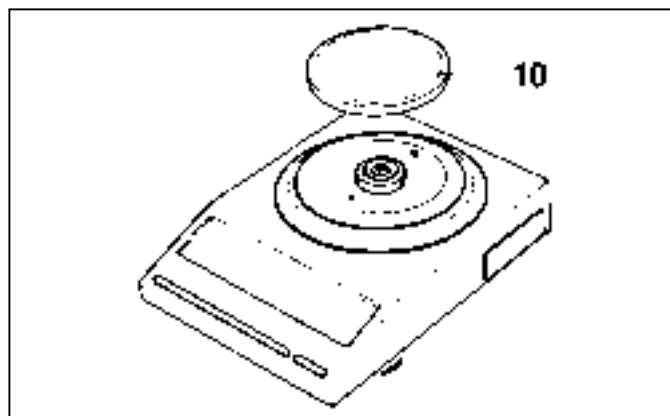

Now place the weighing pan **10** on the balance.

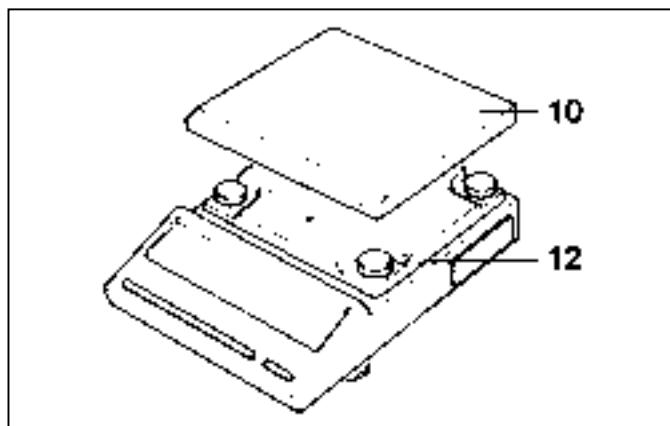

1.3 To mount the square weighing pan

Place pan **10** on the four plastic pads **12**.

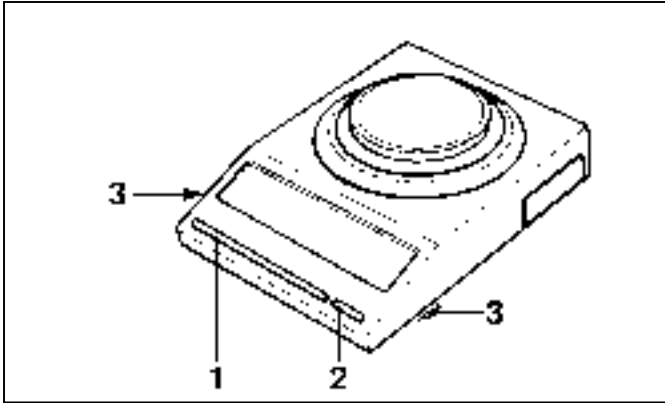

1.4 Controls

- 1 Control bar (ON, menu, tare key)
- 2 PRINT key
- 3 Leveling feet

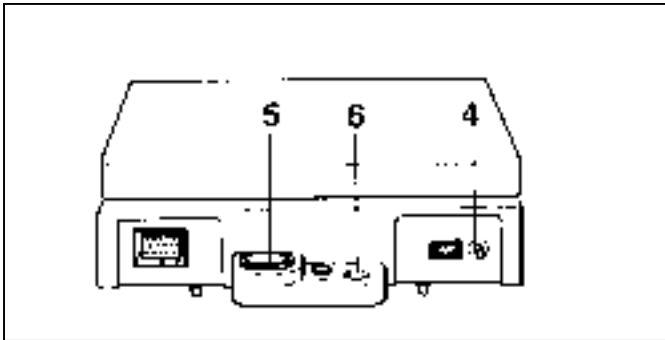

- 4 OFF button
- 5 Bubble indicator (level check)
- 6 Hole for anti-theft chain

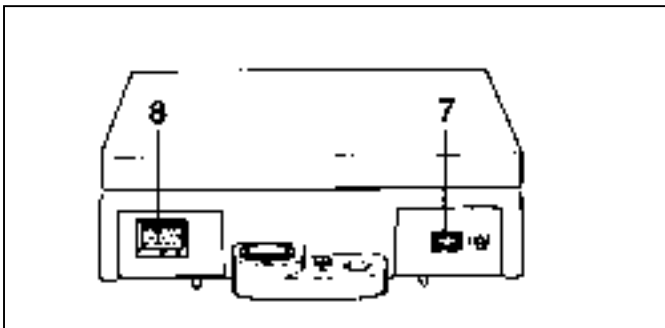

1.5 Connections

- 7 Mains adapter socket (power supply)
- 8 Socket for data interface

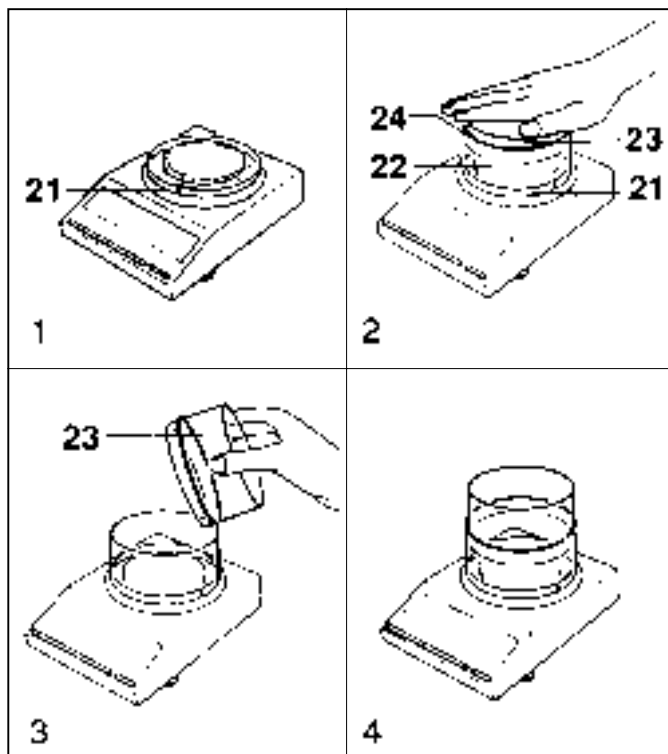

1.6 Draft shield

We recommend fitting the draft shield provided, so that your results are not affected by air movements. The procedure is as follows:

- 1 Put ring **21** on the balance.
- 2 Put glass cylinder **22** into the ring **21** and insert the smaller glass cylinder **23** with adjusting ring **24** into the bigger glass cylinder. Now press on glass cylinder **23** till it lies on the ring **21**.
- 3+4 Remove the smaller glass cylinder **23** and invert, then put the cylinder in as deep as required by the weighing.

Note:

If your balance has a square pan, your METTLER TOLEDO dealer can supply a suitable draft shield. (See datasheet "Technical data and accessories" 704036)

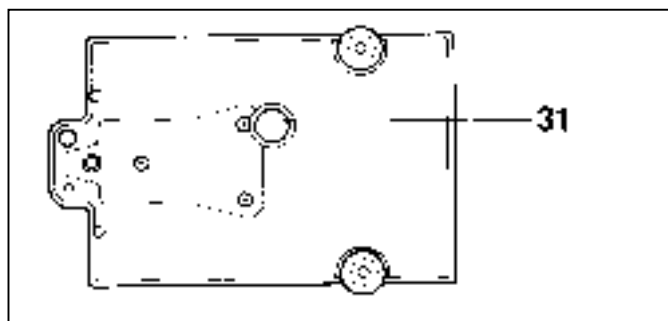

1.7 Hanger access

Plastic cap **31** can be removed, giving access to a hanger for weighing underneath the balance. The weighed item may be suspended at this point.

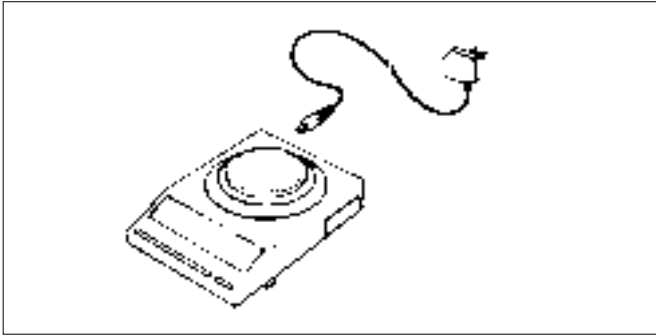

1.8 Connecting the mains adapter (power supply)

Now connect the balance (socket 7) to the power supply with the mains adapter provided. The mains adapter is suitable for the power supply in your country.

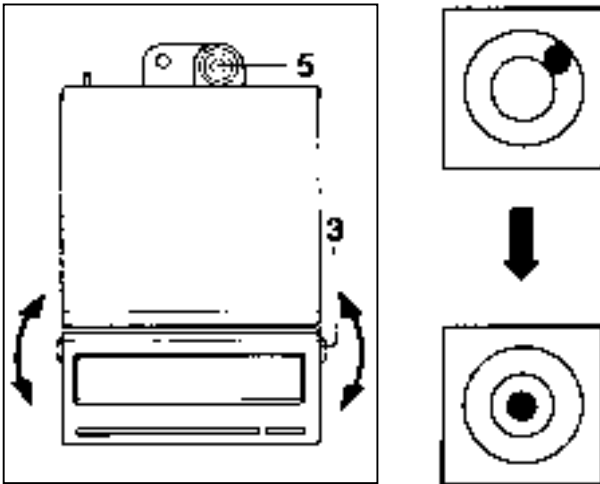

1.9 Set the balance level

To obtain accurate readings, the balance must be set exactly level whenever it is moved to a new place.

To level the balance, turn the screw feet **3** in the appropriate direction until the bubble is in the center of level indicator **5**.

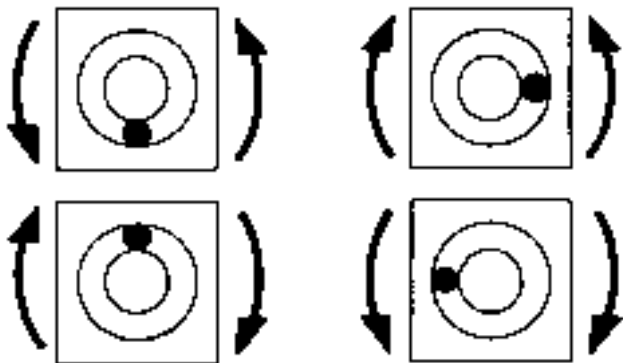

2. Operation

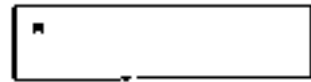

2.1 Display symbols

More details in:

Indicates standby and special status

The balance is ready (mains adapter plugged in) but not yet switched on, i.e. display is blank.

Section 2.3

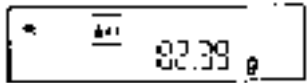

A calculated weighing result

This is a calculated value (i.e. weighing under difficult conditions or weighing animals).

Section 2.7

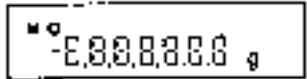

System and segment check

When you switch on the display, all the segments light up.

Section 2.3

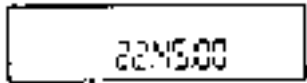

Software number

For information only (e.g. 22.45.00).

Section 2.3

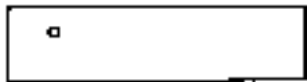

Indicates stability detector

Appears if weighing result is unsteady.

Section 2.8

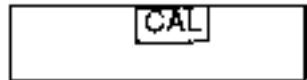

Calibrating

With this setting you can calibrate the balance.

Section 2.3

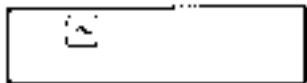

Vibration adapter

With this setting you can adjust your balance to the ambient conditions.

Section 2.5

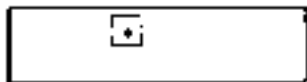

Weighing process adapter

With this setting you can adjust the balance to what you type of weighing.

Section 2.6

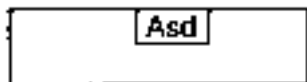

Stability detector

At this setting you can alter the limit of the stability detector.

Section 2.8

2.2 Operating symbols

You will come across these symbols throughout the operating instructions.

Briefly

press
control bar.

Keep control bar depressed

until required
readout appears,
then release.

Display
changes
automatically.

2.3 Short instructions

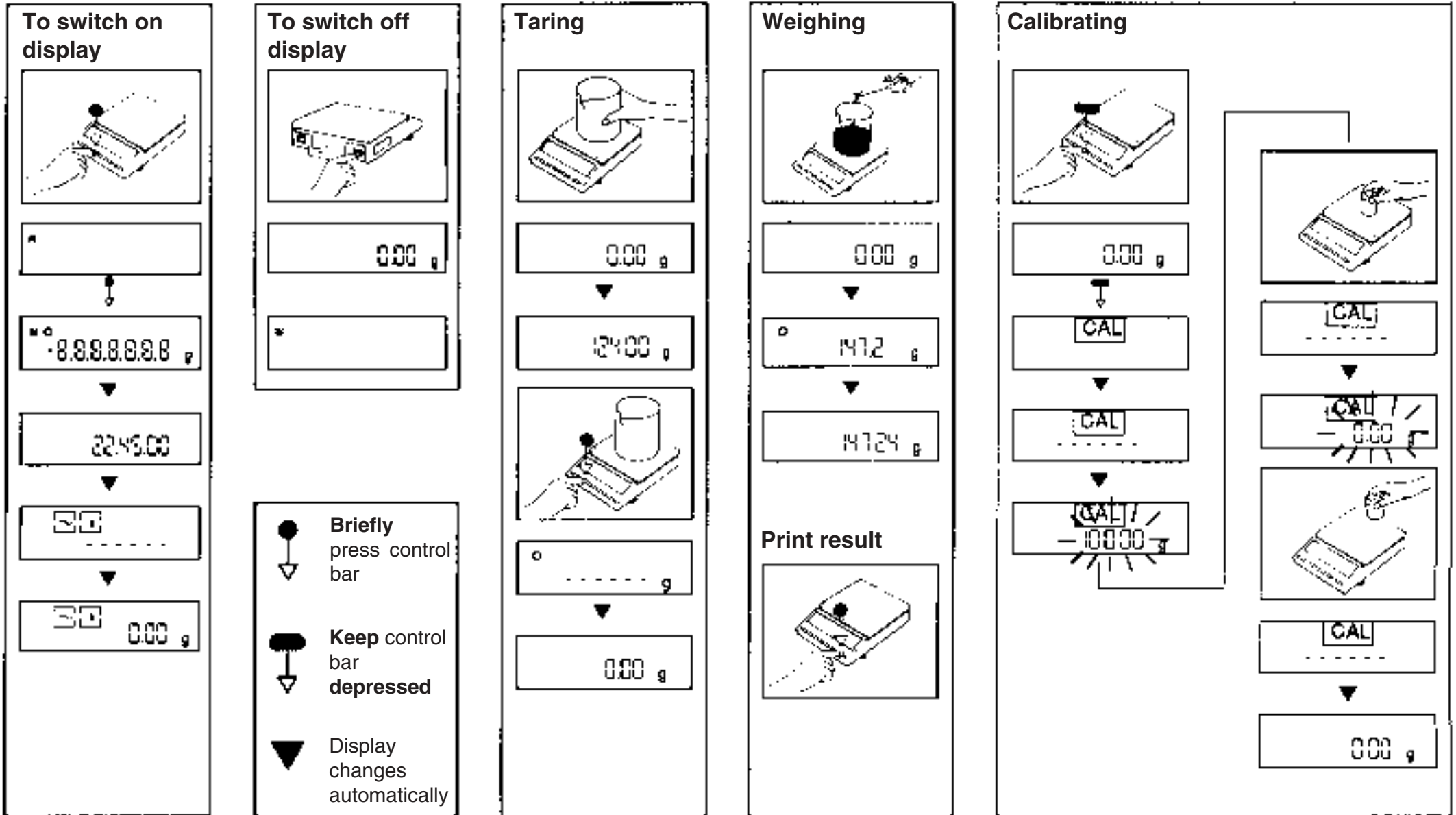

**Adjusting to ambient conditions -
Vibration adapter**

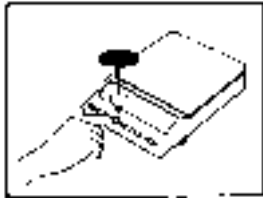

0.00 g

CAL

2



Surroundings
very steady

2

Surroundings
normal

2

Surroundings
unsteady

2

**Adjusting to weighing process -
Weighing process adapter**



0.00 g

CAL

2

2



Fine dispensing

2

Universal

2

Absolute weighing

2

Weighing
under difficult
conditions

2

Adjusting stability detector



0.00 g

CAL

2

2

Asd

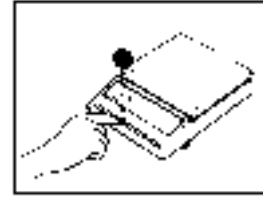

Coarse

Asd
-1-

Standard

Asd
-2-

Fine

Asd
-3-

Very fine

Asd
-4-

METTLER TOLEDO Delta Range®

The METTLER TOLEDO Delta Range® scale has a ten times more accurate fine range. By means of a keystroke (taring) this fine range can be called up over the entire weighing range **at any time**.

Note:

The 10 times more accurate fine range is also available during subtractive weighing.

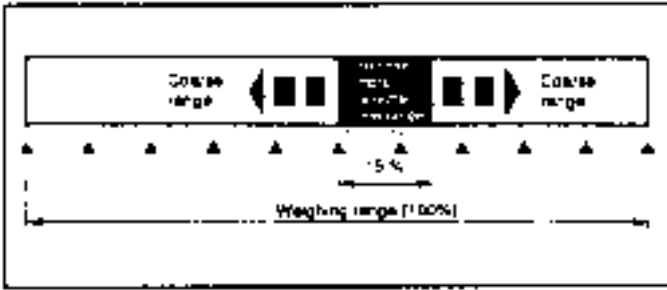

2.4 The menu

A distinction is made between two levels of operation: the first level is the **menu**. When the balance is in weighing mode, you can run through all the menu steps by keeping the control bar depressed.

The second control level is the **configuration file**, described in detail in Section 3.1 “The configuration file”.

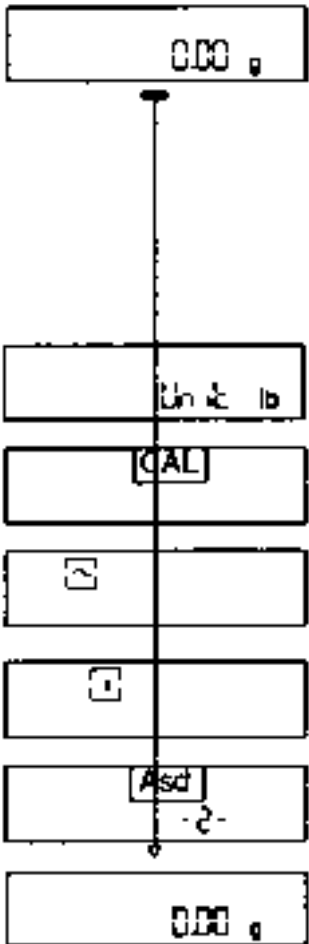

... to **change the unit** ... (appears only if selected Unit 1 is different from Unit 2 (Section 3.3)).

... to **calibrate** the balance ... (Section 2.3)

... to **adjust the balance to ambient conditions** ... (Section 2.5)

... to **adjust the balance to the weighing process**... (Section 2.6, 2.7)

... to alter the condition (limits) for **detecting stability** (Section 2.8)

Note:

If you release the control bar, the display returns automatically to weighing mode after about 3 seconds.

2.5 Adjusting the balance to ambient conditions - Vibration adapter

When weighing under conditions where vibrations or drafts effect the weighing results, set the vibration adapter so that the balance stabilizes in the shortest possible time.

Enter the menu as described in section 2.4 and then select the desired setting by briefly pressing the control bar.

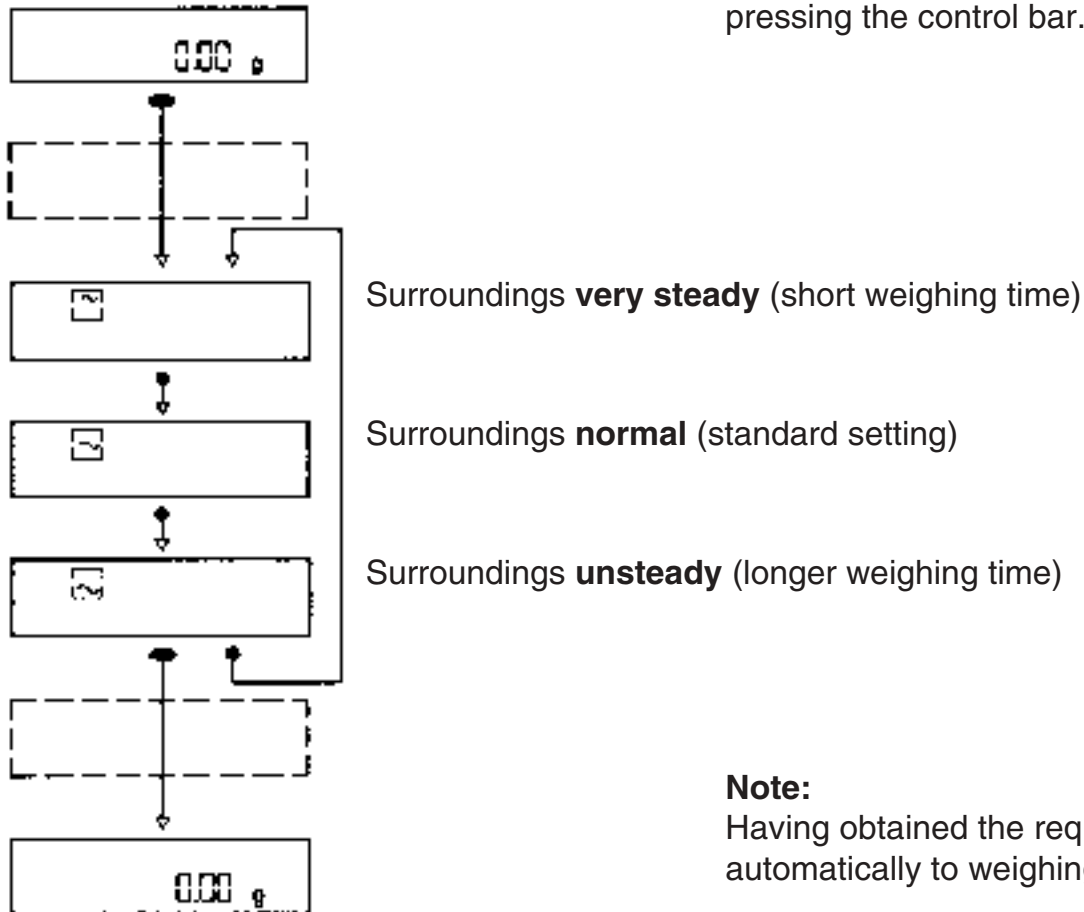

Note:

Having obtained the required setting, do not touch the control bar again. The display returns automatically to weighing mode after about 3 seconds.

 Factory setting

2.6 Adjusting the balance to the weighing process - Weighing process adapter

With this adjustment you optimize the display's response according to what you are weighing. When **finely dispensing** powders, for example, the display's last digit must be visible all the time.

This is not the case with **absolute weighing**, so the display is blank while the balance is settling. The result appears when stability is reached.

Call up the menu as described in Section 2.4 and then select the required setting by briefly pressing the control bar:

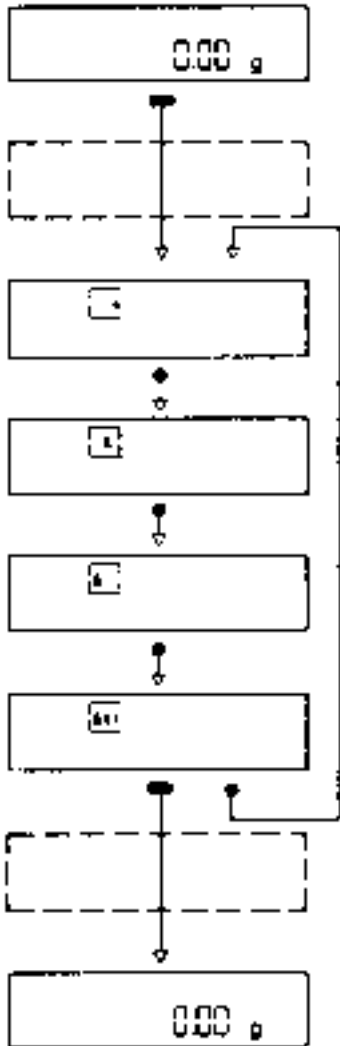

Fine dispensing

All decimal places are displayed while dispensing.

Universal (factory setting)

While dispensing/weighing, the last digit is suppressed until stability is achieved.

Absolute weighing

Display shows ----- until balance is stable.

Weighing under difficult conditions, e.g. weighing animals (see Section 2.7).

Note:

Having obtained the required setting, do not touch the control bar again. The display returns automatically to weighing mode after about 3 sec.

 Factory setting

2.7 Weighing under difficult conditions, weighing animals

If the balance will not settle due to extreme vibration or when weighing animals, select the setting “Weighing under difficult conditions” as described in Section 2.6. Movements then no longer affect the display. In this case the readings are averaged over a certain length of time. The calculated result is then displayed, together with the standby indicator.

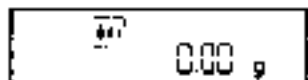

Place specimen in container.

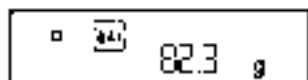

Movement prevents the display from stabilizing.



To initiate weighing, briefly press the PRINT key.

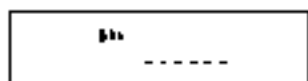

The balance now calculates the average of a large number of readings. (The readings are integrated.)

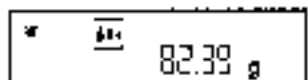

Read off the calculated value.

The display remains steady for about 3 - 5 sec. giving you time to read it.

Note:

Select the cycle time (integration time + readout time) and hence the weighing accuracy by choosing the appropriate setting for “Adjusting to ambient conditions vibration adapter” (Section 2.5):

about 4 sec./

about 6 sec./

about 9 sec.

2.8 Adjusting the stability detector

The stability detector (Section 2.1) remains on the display until fluctuations in the reading are within a specified tolerance; the result is then considered stable. Until then, taring is not completed and the print out of results may be inhibited.

Four tolerances can be selected, according to surroundings and required accuracy:

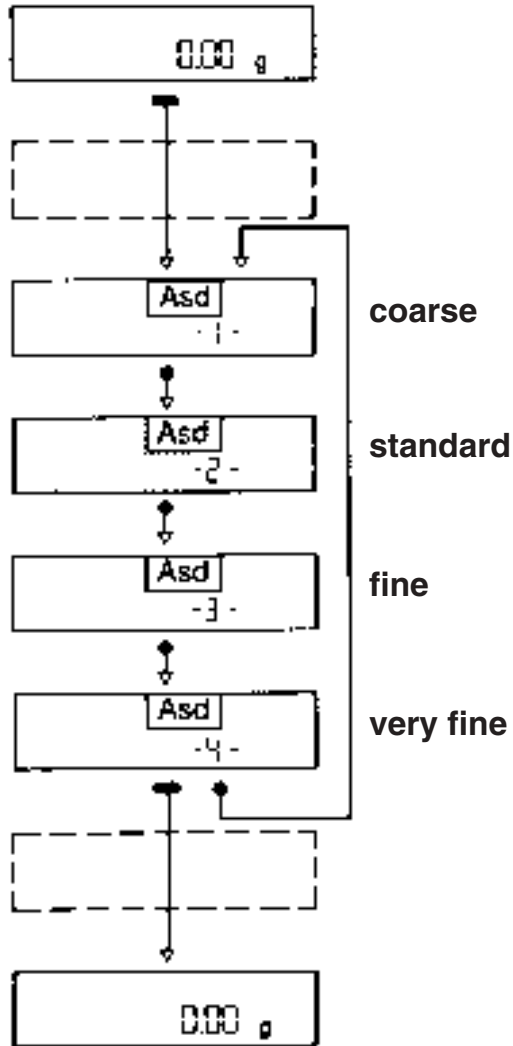

for good results in unsteady surroundings; stability is assumed despite slight fluctuations.

(factory setting)

for optimum results; a stable state is not assumed until fluctuations have virtually ceased.

Note:

Having obtained the required setting, do not touch the control bar again. The display returns automatically to weighing mode after about 3 seconds.

 Factory setting

3. Configuring

3.1 The configuration file

Your balance has been factory-set to a standard configuration, i.e. the settings in the configuration file correspond to the most common user requirements. However, if you wish to adapt your balance to special needs, you can access the configuration file and alter the settings to meet your requirements. To do this, the jumper must be set to the “not secured” position (Section 3.5). The configuration file is divided into three sectors in which you can alter the settings listed below.

To access the configuration file, first switch off the balance. This is done by pressing the OFF button at the rear of the balance.

Now press the control bar until -ConF- appears, then release it. More details in:

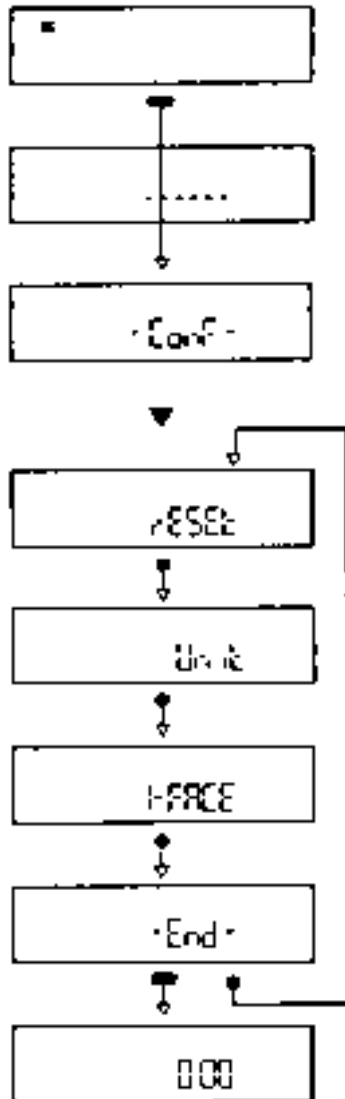

Return to factory setting (rESET) Section 3.2

Selection of units (Unit) Section 3.3

Adjusting the interface to external equipment (I-FACE) Section 3.4

Note:

Holding the control bar down always returns you to the menu. If you do not press the control bar for **40 seconds**, the balance returns **automatically** to the weighing mode. The altered settings are then stored in the configuration file.

3.2 To return to factory setting

In the rESET sector of the configuration file you can restore the factory settings in menu and configuration file.

Reset to factory setting Yes/No

Printout of balance parameters Yes/No

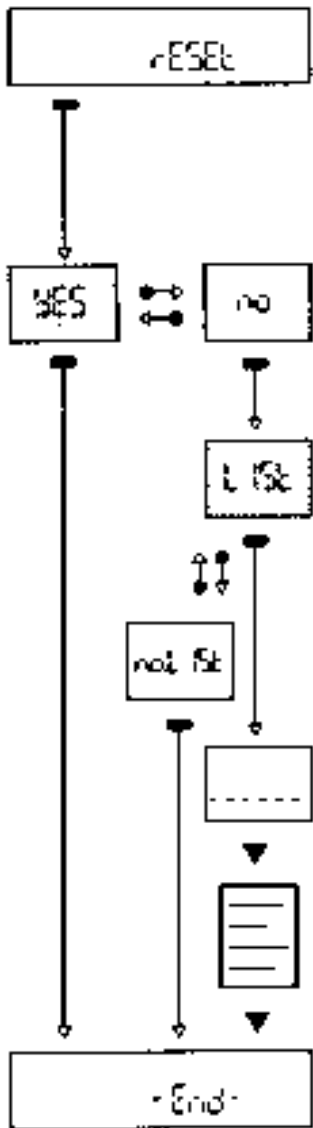

 Factory setting

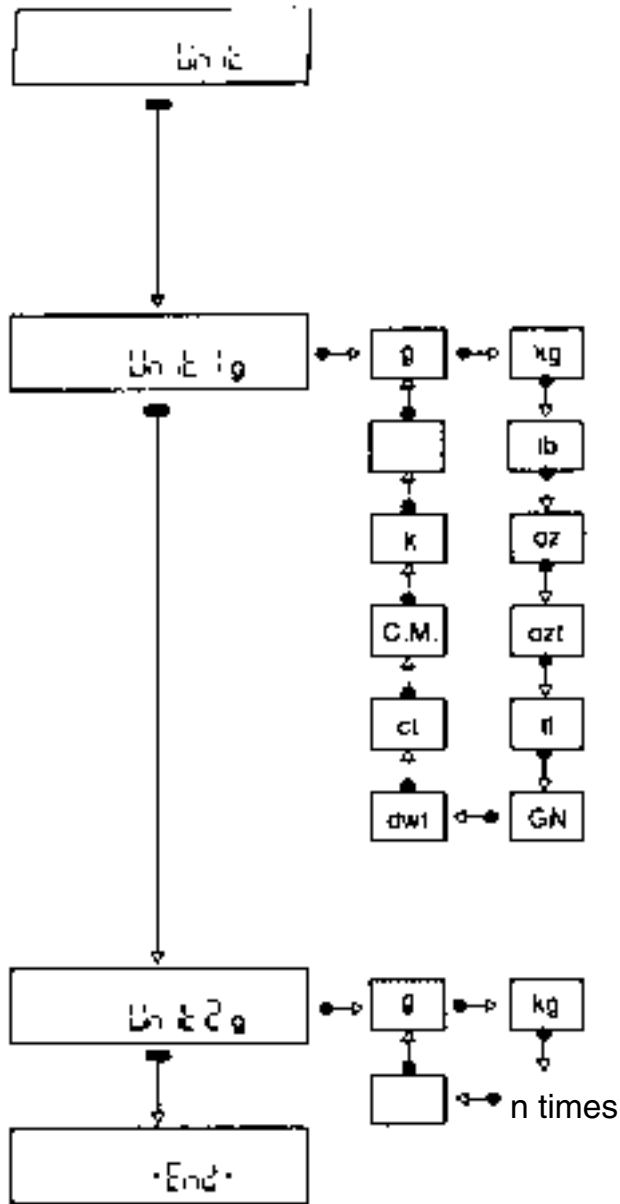

3.3 Selection of units

The balance has been factory-set to the basic unit g (gram). However, you can define another basic unit, and also a switchable second unit.

Basic weight unit

Apart from grams (g) the balance can be used to weighing any of the following weight units:

<input type="checkbox"/> g	gram	<input type="checkbox"/> ozt	troy ounce	<input type="checkbox"/> ct	} carat	* not for BB600/1200/3000/3	
<input type="checkbox"/> kg	kilogram	<input type="checkbox"/> tl	tael	<input type="checkbox"/> C.M.			
<input type="checkbox"/> lb	pound	<input type="checkbox"/> GN	grain*	<input type="checkbox"/> k			
<input type="checkbox"/> oz	ounce	<input type="checkbox"/> dwt	pennyweight	<input type="checkbox"/>			no unit displayed (reading in grams)

Switchable second unit

Under Unit 2 you have the same choice of units as with the basic unit (Unit 1).

To switch between units

If you have selected a Unit 2 which is different from Unit 1, in weighing mode you can switch between the two units by prolonged pressure on the control bar (Section 2.4).

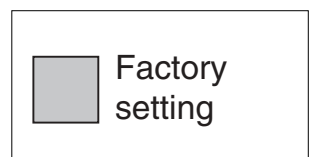

3.4 Adjusting the interface to external equipment

For detailed information on the interface, please refer to separate instructions for interface (Order No. 704097).

Your balance has been **factory-set** for use with a METTLER TOLEDO printer. If you want your weighing results on a printer or to send them to a computer, the interface must be set correctly in order to ensure error-free data transfer.

Data transfer mode

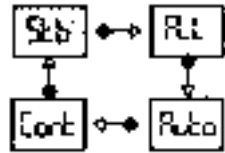

Baud rate in bit/sec.

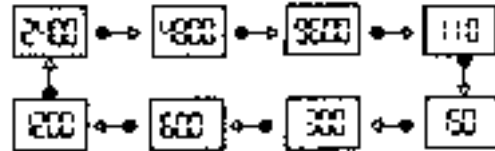

Parity

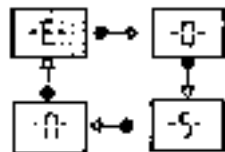

Pause between transmission in sec., or hardware handshake (HS)

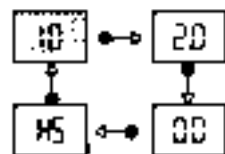

off: Transfer of certification symbols (<=>) or of * when weighing under difficult conditions.
(Display not possible with all peripherals)

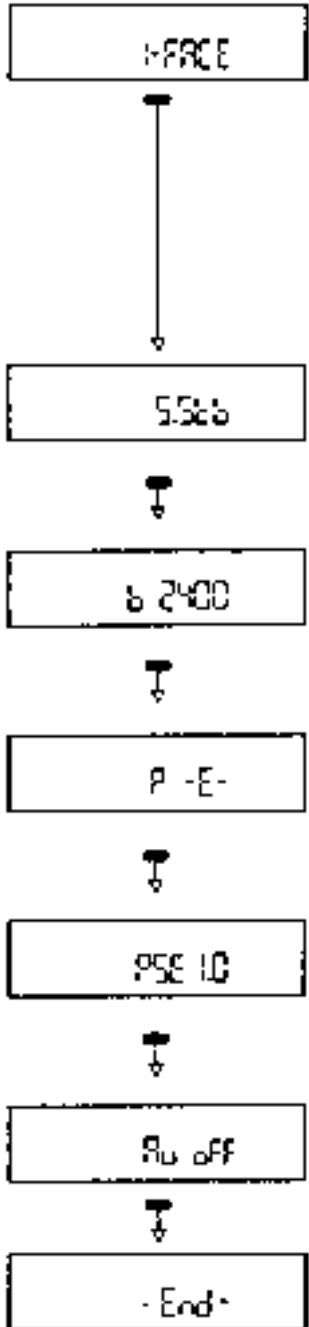
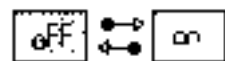

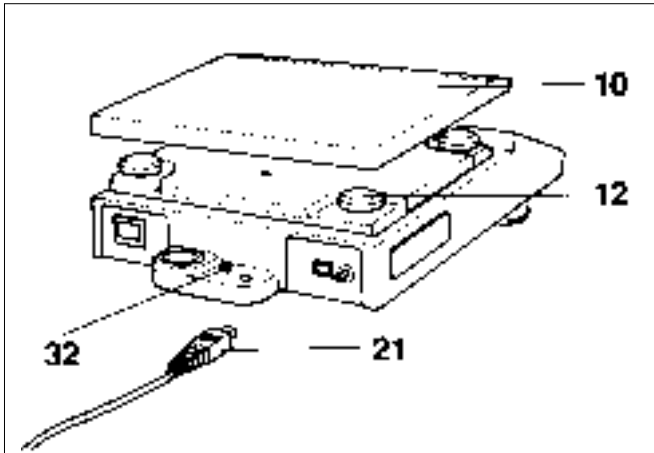

3.5 Securing the settings in the configuration file

Having configured your balance, you can protect the chosen settings against accidental alteration. The procedure is as follows:

Pull out mains adapter plug **21** and lift off weighing pan **10**. If your balance has a square pan, remove the four plastic pads **12**. Now you can undo screw **32**, raise the housing at the back, and lift it off forwards.

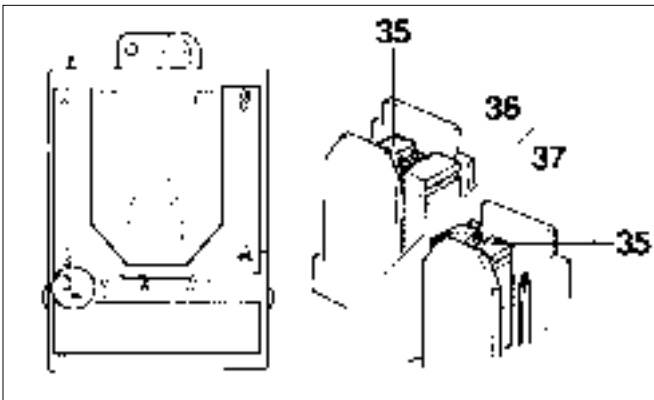

Using tweezers, detach jumper **35** and re-insert it in the “secured” position.

Position 36 not secured

Position 37 secured

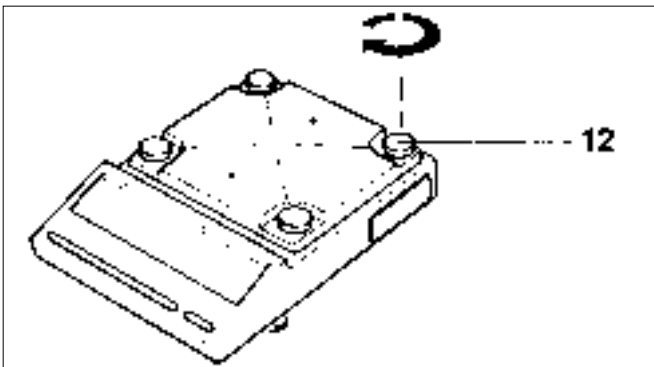

Now put back the housing and insert the plastic pads **12** with a twisting motion until they turn easily. Fasten screw **32** and put on the weighing pan.

Your settings can now no longer be altered with the control bar; it is no longer possible to access the configuration file as described in Section 3.1.

4. Miscellaneous

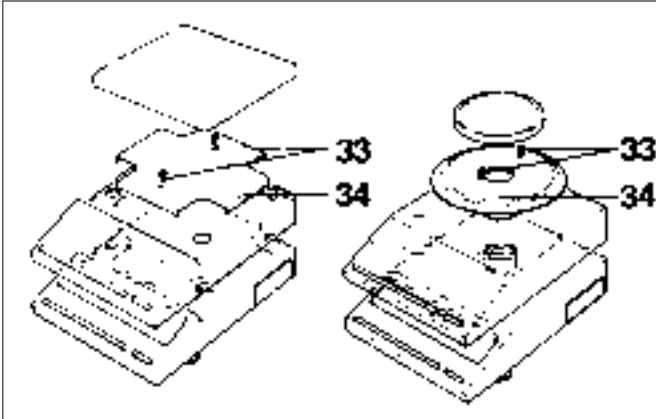

4.1 To change the in-use cover

Lift off weighing pan. Undo the two screws **33** and remove retaining plate **34**. Take off the old in-use cover and fit the new one. Put back retaining plate **34** and fasten it with the two screws **33**. Place pan on balance.

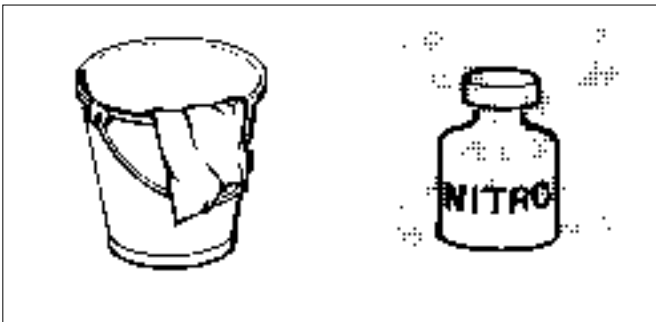

4.2 Cleaning the balance

Your balance needs cleaning occasionally. A cloth and some soapy water is all you need to clean the pan and housing.

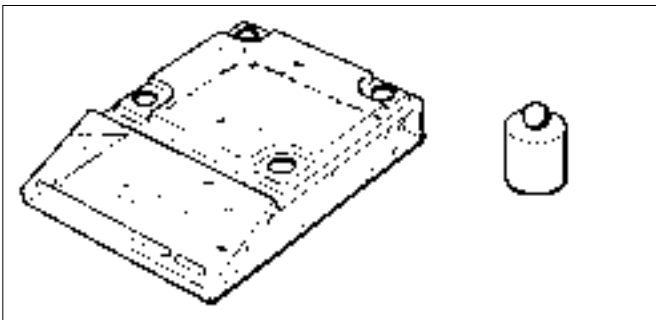

Never use strong solvents!



4.3 Accessories

Spare in-use covers, calibration weight and other useful accessories are to be found in the datasheet "Technical data and accessories" Order No. 704036.

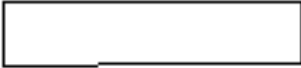
5. What to do if... (A guide to trouble-shooting)

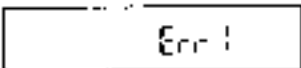
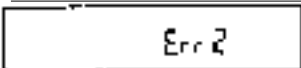
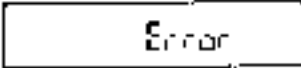
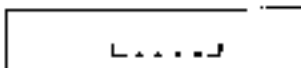
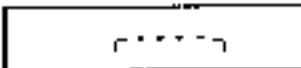
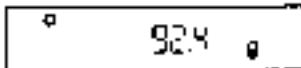
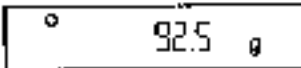
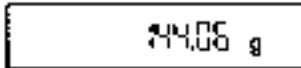
Display	Signifies	Cause	Remedy
	Display blank	<ul style="list-style-type: none"> - mains adapter not plugged in - no power 	<ul style="list-style-type: none"> - plug in mains adapter - check power supply
	Standby	<ul style="list-style-type: none"> - temporary power failure - OFF button pressed 	<ul style="list-style-type: none"> - check mains adapter for good fit, then tare - switch on balance
	Instruction to calibrate or tare not executed	<ul style="list-style-type: none"> - wrong calibration weight - balance unstable - waiting time for calibration expired 	<ul style="list-style-type: none"> - use correct calibration weight - adjust as described in Section 2.5 and 2.8
	Zero not defined	<ul style="list-style-type: none"> - pan not in place 	<ul style="list-style-type: none"> - place pan on balance
	Error message by internal electronics monitor during automatic self-check	<ul style="list-style-type: none"> - permitted temperature range exceeded, or fault 	<ul style="list-style-type: none"> - pull out mains adapter and plug in again - if error message persists, contact METTLER TOLEDO Service
	Underload	<ul style="list-style-type: none"> - pan not in place - in-use cover touching pan - weight below weighing range 	<ul style="list-style-type: none"> - place pan on balance - position in-use cover correctly - tare balance
	Overload	<ul style="list-style-type: none"> - weight beyond weighing range 	<ul style="list-style-type: none"> - reduce weight on balance
 	Weighing result unstable	<ul style="list-style-type: none"> - unstable weighing location 	<ul style="list-style-type: none"> - adjust as described in Sections 2.5 and 2.8.
	Result very inaccurate	<ul style="list-style-type: none"> - operating error - balance not calibrated - in-use cover touching pan 	<ul style="list-style-type: none"> - remove weight, tare, repeat weighing - calibrate balance - position in-use cover correctly

Printed on 100 % chlorine-free Paper, for the sake of our environment.

**To protect your METTLER TOLEDO product's future:
METTLER TOLEDO Service assures the quality, measuring accuracy and
preservation of value of all METTLER TOLEDO products for years to
come.**

**Please send for full details about our attractive terms of service.
Thank you.**



P703447

Subject to technical changes and to the availability
of the accessories supplied with the instruments.

© Mettler-Toledo GmbH 1998 703447A Printed in Switzerland 9808/2.12

Mettler-Toledo GmbH, Laboratory & Weighing Technologies, CH-8606 Greifensee, Switzerland
Phone +41-1-944 22 11, Fax +41-1-944 30 60, Internet: <http://www.mt.com>