

NC1000 Series

10 Hz to 10 GHz



Amplified Noise Modules

The NC1000 series modules produce white Gaussian noise up to +13 dBm. The high power modules are designed for secure communication and signal jamming, while the low power modules with high crest factor are used for signal impairment in BER, and Jitter applications.

Each module contains a hermetically packaged noise diode that has been pre-selected for special performance characteristics. The standard module is designed for a 50 Ω load impedance.

Applications

- CATV/HDTV
- Signal jamming
- Secure communications
- Jitter applications
- 10 GigE, PCI Express

Specifications

High power	Up to +13 dBm
Standard input Voltage	+28VDC (below 1.5 GHz) +15 VDC (above 1.5 GHz)
Operating temperature	-35° to +100°C
Storage temperature	-65° to +150°C
Typical temperature coefficient	0.025 dB/°C
Supply voltage sensitivity	0.25 dB/1% Δ V
Output connector	SMA female connector (BNC available as option)

Options

NC1opt01	+15 VDC
NC1opt02	+24 VDC
NC1opt03	BNC female connector (NC1101A through NC1110A only)
NC1opt04	0 dBm output (Package 2, NC1101A through NC1110A) Not available for NC1124, NC1126 & NC1128
NC1opt05	TTL control "High" is on (add "T")
NC1opt06	TTL control "Low" is on (add "IT")
NC1opt07	Special frequency range (consult factory)

High Power Modules

50 Ω Load Impedance (Package 1, +28 VDC Operation is standard)

Model	Frequency Range	Output Characteristics				I (max) (mA)
		Power (dBm)	dBm/Hz	Flatness (dB)	$\mu\text{V}/\Delta\text{Hz}$	
NC1101A	10 Hz - 20 kHz	+13	-30	± 0.5	7071	70
NC1103A	10 Hz - 500 kHz	+13	-44	± 0.5	1414	150
NC1105A	10 Hz - 10 MHz	+13	-57	± 0.75	316	160
NC1107A	100 Hz - 100 MHz	+13	-67	± 1.0	100	160
NC1108A	100 Hz - 500 MHz	+10	-77	± 1.5	31.6	160
NC1109A	100 Hz - 1 GHz	+10	-80	± 2.0	22.4	160
NC1110A	100 Hz - 1.5 GHz	+10	-82	± 2.0	18.2	160

High Crest Factor Modules

50 Ω Load Impedance (Package 3, +15 VDC operation is standard)

Model	Frequency Range	Output Characteristics				I (max) (mA)
		Power (dBm)	dBm/Hz	Flatness (dB)	$\mu\text{V}/\Delta\text{Hz}$	
NC1111A	1 GHz - 2 GHz	-10	-100	± 2.0	2.24	250
NC1111B	1 GHz - 2 GHz	0	-90	± 2.0	7.07	250
NC1112A	20 MHz - 2 GHz	-10	-103	± 2.5	1.58	250
NC1112B	20 MHz - 2 GHz	0	-93	± 2.5	5.02	250
NC1113A	10 MHz - 3 GHz	-10	-105	± 2.5	1.12	250
NC1113B	10 MHz - 3 GHz	0	-95	± 2.5	5.02	250
NC1124A	2 GHz - 4 GHz	-10	-103	± 2.5	1.58	250
NC1126A	2 GHz - 6 GHz	-14	-110	± 2.5	0.71	250
NC1128A	10 MHz - 10 GHz	-17	-117	± 3.0	0.32	250

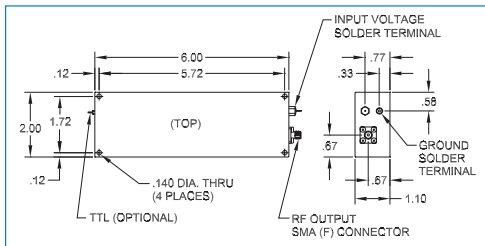

NC1000 Series Dimensions - Package 1 (inches)

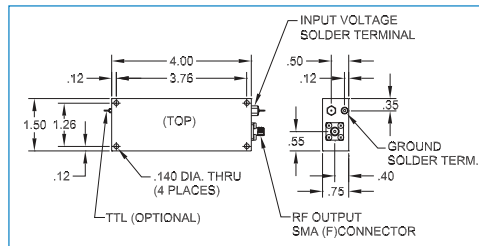

NC1000 Series Dimensions - Package 2 (inches)

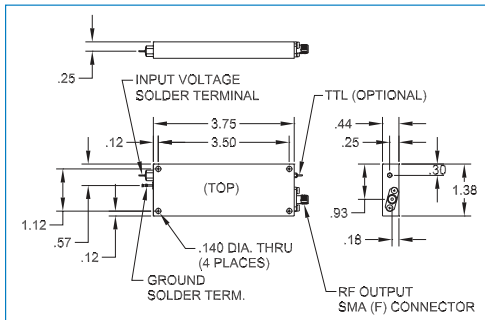

NC1000 Series Dimensions - Package 3 (inches)

Wireless Telecom Group Inc.
 25 Eastmans Rd
 Parsippany, NJ
 United States
 Tel: +1 973 386 9696
 Fax: +1 973 386 9191
www.noisecom.com

© Copyright 2011
 All rights reserved.

N/NC1000/811/EN
 Note: Specifications, terms and conditions
 are subject to change without prior notice.